

Champion®

The Dishwashing Machine Specialists

Project _____
 Item No. _____
 Quantity _____

UH230B UNDERCOUNTER

STANDARD FEATURES

- **ENERGY STAR® Qualified**
- **NEW "Shear Energy"** – a reduction in energy requirements while maximizing performance!
- **NEW "Multi-Power"** – includes **"Multi-Volt"** and **"Multi-Phase"**. Allows for infield conversion to 208-240 volt and/or single to three phase with ease.
- **StemSure™** – Soft start to protect glasses and dishes from chipping and breaking
- **Rinse Sentry** – extends the cycle time to ensure 180°F/82°C final rinse.
- **Built-in electric booster** for 180°F/82°C final rinse water (standard 70°F/39°C rise)
- Pumped drain
- Low-water tank heat protection
- Detergent and rinse aid pumps
- Quiet double-wall construction
- Door safety switch
- Independent stainless steel interchangeable upper and lower wash and rinse arms
- Top mounted slide-out controls
- Stainless steel top and side panels
- 90-second total cycle time
- Extended wash for difficult ware cleaning & de-liming
- Automatic drain cycle
- 1 Hp motor
- Advanced Digital Temperature Monitoring
- Stainless steel construction

UH230B

Undercounter High Temperature Dishwashing Machine with Built-in Booster Heater



NEW FEATURES

Photo is for general visual representation only. Please refer to specifications for the latest detailed product information.



SPECIFIER STATEMENT

Specified unit will be Champion model UH230B undercounter high temperature dishwashing machine with built-in booster heater.

Features 90 second total cycle, extended wash, LED temp display, Rinse Sentry, rinse aid and detergent pumps, flexible fill and drain hoses, stainless steel top and side panels. Constructed of stainless steel.

1 year parts and labor warranty.

OPTIONS & ACCESSORIES

- 1-RDT Dish Table** Durable, heavy-gauge stainless steel dish table with sink, stand-pipe drain, removable scrap screen holder, drain-board, backsplash and lower storage cabinet. Sprayhose is optional. See 1-RDT catalog sheet) Specify right hand or left hand sink.
- Additional Dish Racks**
- 17" Stand** Stainless Steel
- 6" Leg Stand**
- 3 Phase Connection (prewired at factory)**
- 9kW High Speed Rise Booster**
- UH230B without Booster**
- 1" Roller Kit (includes 4 casters)**
- Power Cord kit**

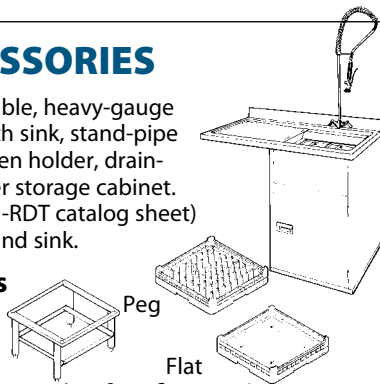

UH230B

Undercounter High Temperature Dishwashing Machine with Built-in Booster Heater

Champion®

The Dishwashing Machine Specialists

Volume crated: **15 cu. ft./0.42 cu.m.**
 Shipping weight crated: **215 lbs./97.5 kg.**

Dimensions shown in inches and [millimeters]

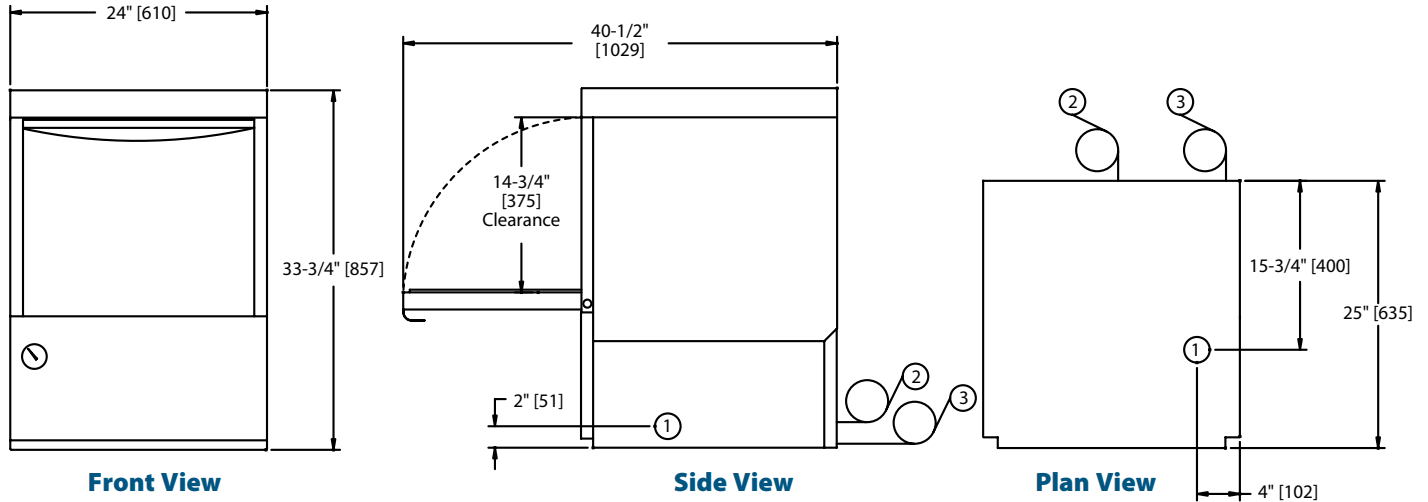

Utilities	
1 Electrical	208-240/60/1; 3 wire plus ground, (See Box). 208-240/60/3; 4 wire plus ground, (See Box). Field convertible to accept 3 phase power, see service manual for details
2 Hot Water	1/2" supply; 110°F/43°C Min. hot water connection for 70°F/39°C rise booster. Incoming supply pressure must maintain a Flow pressure of 20-22 PSI. If machine is sold without internal booster, a 1/2" PRV is required to be purchased. Machine equipped with 3/4" [19] hose connector.
3 Pumped Drain	5/8" [15.9] I.D. flexible reinforced hose, 6 ft. [1829] long. Max. drain flow 15 US gpm. [12.5 imp gal] Max. drain height 3 ft. [914]

SPECIFICATIONS

Capacities*	
Cycle time (seconds)	90
Racks per hr.	40
Motor horsepower	
Wash	1
Water consumption	
U.S. Gal./Imperial Gal. (Max. use) per hr.	23.4/19.2
U.S. Gal./Imperial Gal. per rack	0.78/0.64
Temperatures °F/°C	
Wash	150/66
Rinse	180/82
Heating	
Tank heat, electric, kW	2.0
Electric booster (kW) (required for 70°F/39°C rise)	6
Electric high speed booster (kW)	9
Time Cycle in Seconds	
Wash	70
Rinse	14
Total cycle	90
Standard 20" x 20" [508 x 508] Rack Complement	
Dish	1
Open	1
* at 140° incoming water	

6kW UH230B with 70°F/39°C Rise Booster

Elec. Specs.	Rated Amps	Minimum Supply Ckt. Conductor Ampacity	Maximum Overcurrent Protective Device
208/60/1	32	40	40
240/60/1	36	40	40
208/60/3	22	30	30
240/60/3	24	30	30

UH230B with 9kW High Speed Booster

Elec. Specs.	Rated Amps	Minimum Supply Ckt. Conductor Ampacity	Maximum Overcurrent Protective Device
208/60/1	45	60	60
240/60/1	50	60	60
208/60/3	29	35	35
240/60/3	33	40	40

Field convertible to accept 3 phase power

Warning Plumbing and electrical connections should be made by qualified personnel who will observe all the applicable plumbing, sanitary and safety codes and the National Electrical Code.

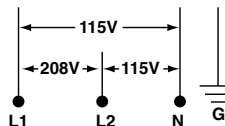

Note: Electrical supply service must be a 3-wire plus ground for connection shown.

UH230 without booster 750 Watt tank heat	
Elec. Specs.	Rated Amps
115/60/1	12

Due to an ongoing value analysis program at Champion, specification contained in this catalog are subject to change without notice.

Champion Industries, Inc., 3765 Champion Blvd, Winston-Salem, NC 27105 • 336/661-1556 • Fax: 336/661-1979 • www.championindustries.com
 2674 N. Service Road, Jordan Station, Ontario, Canada L0R 1S0 • 800/263-5798 • Fax: 905/562-4618