

Glass Door Merchandisers

Swing Door Models



TGM-5R

TGM-11RV

TGM-14RV

TGM-22RV

FEATURES / BENEFITS

- **EFFICIENT REFRIGERATION SYSTEM**
Turbo Air glass door refrigerators are designed with oversized and balanced (CFC Free R-134A) refrigeration systems. These include efficient evaporators and condensers for faster cooling and greater efficiency.
- **TASTEFUL AND MODERN APPEARANCE**
The design of our products is one of our top priorities. Whether you have a restaurant, bar, convenience store or gas station, Turbo Air refrigerators will compliment the appearance of your operation.
- **DOUBLE PANE GLASS DOORS WITH HEAT REFLECTING FILM**
Equipped with unique double pane glass doors with a layer of patented, transparent thermal insulating film applied between the two glass layers. Lightweight door construction reduces door maintenance and roller wear, and facilitates smooth door.
- **MAGNETIC DOOR GASKET**
Magnetic door gaskets are of one piece construction, removable without tools for ease of cleaning and replacement.
- **ADJUSTABLE, HEAVY DUTY, PE(POLYETHYLENE) COATED WIRE SHELVES**
- **HIGH-DENSITY POLYURETHANE INSULATION**
The entire cabinet structure is formed-in-place using high density, CFC free polyurethane insulation.
- **ERGONOMICALLY DESIGNED DOOR**
Customers' fatigue fades away with easy grip handles and doors that open effortlessly. These features along with self-closing doors make this the ultimate choice in customer convenience.
- **HOT GAS CONDENSATE SYSTEM**
Through Turbo Air's creative innovation, the condensate system surfaces have been specially treated to resist corrosion. This not only increases efficiency without the risk of refrigerant leakage from corrosion, but thoroughly prevents the overflow of condensate water (except TGM-5R).
- **BOTTOM MOUNT COMPRESSOR UNITS**
Turbo Air's bottom mount compressor allows easier access for service and extra storage space above. In addition, the lower area provides a cooler and less greasy operating environment which results in reduced compressor running time.
- **REFRIGERATOR HOLDS 33°F ~ 38°F FOR THE BEST IN BEVERAGE PRESERVATION**

* Actual shelf organizer may differ in appearance than above picture.

Model	Swing Door	CU./FT.	#of Shelves	HP	AMPS	Crated Weight	L D H
TGM-5R	1	5	3	1/10	22	82	19 x 23 ³ / ₅ x 33 ⁵ / ₇
TGM-11RV	1	11	4	1/4	54	163	23 ³ / ₅ x 24 ⁴ / ₅ x 63 ⁵ / ₇
TGM-14RV	1	14	4	1/4	63	187	23 ³ / ₅ x 26 ¹ / ₉ x 73 ³ / ₅
TGM-22RV	1	22	4	1/4	76	243	28 ² / ₃ x 30 ¹ / ₅ x 79 ⁵ / ₇

TGM-5R/ TGM-11RV / TGM-14RV / TGM-22RV SPECIFICATIONS

MODEL	TGM-5R	TGM-11RV	TGM-14RV	TGM-22RV
Exterior Dimension(LxDxH)	19x23 ³ / ₅ x33 ⁵ / ₇	23 ³ / ₅ x24 ⁴ / ₅ x63 ⁵ / ₇	23 ³ / ₅ x26 ¹ / ₉ x73 ³ / ₅	28 ² / ₃ x30 ¹ / ₅ x79 ⁵ / ₇
Interior Dimension(in)	16 ¹ / ₅ x17x29 ¹ / ₅	18 ⁸ / ₉ x19 ² / ₃ x44 ⁵ / ₇	19x19 ⁸ / ₉ x57 ¹ / ₂	24 ¹ / ₉ x23 ³ / ₅ x62 ¹ / ₉
Compressor (HP)	1/10	1/4	1/4	1/4
Voltage (NEMA-5-15P)	115V/60Hz	115V/60Hz	115V/60Hz	115V/60Hz
Amp	2.2 A	5.4 A	6.3 A	7.6 A
Power Cord Length	8.6 ft.	6.8 ft.	6.5 ft.	6.2 ft.
Plug-In Installation	NEMA 5-15P	NEMA 5-15P	NEMA 5-15P	NEMA 5-15P
Net Weight	75lbs	137lbs	168lbs	225lbs
Shelves	3EA	4EA	4EA	4EA
Shelf size	A:16 ¹ / ₉ x14 ¹ / ₃ B:16 ¹ / ₉ x15 ² / ₃ C:16 ¹ / ₉ x9	20 ¹ / ₅ x14 ¹ / ₂	A:20 ² / ₅ x16 ⁸ / ₉ B:19 ¹ / ₂ x16 ⁸ / ₉	25 ¹ / ₂ x19 ² / ₅
Bottle Capacity	Full Load Line	114	150 120	280

STANDARD FEATURES

- White color cabinet.
- Black color frame on door.
- Double pane glass door with thermal film.

OPTION

- 2" Plate mount casters.
- Gravity shelves (Fit up to 20 oz bottle)
- Customized graphics & colors available in quantity

*Design and specifications subject to change without notice.

WARRANTY: 1 Year Labor and Parts Warranty
Additional 4 Years Warranty on Compressor



LISTED
COMMERCIAL
REFRIGERATOR
AND/OR FREEZER
43BK



TGM-5R PLAN VIEW

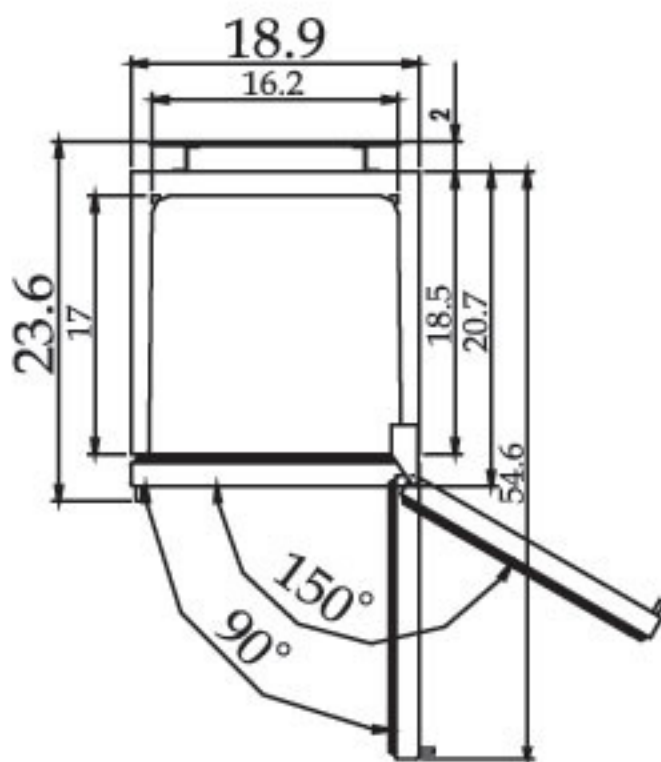

TGM-11RV PLAN VIEW

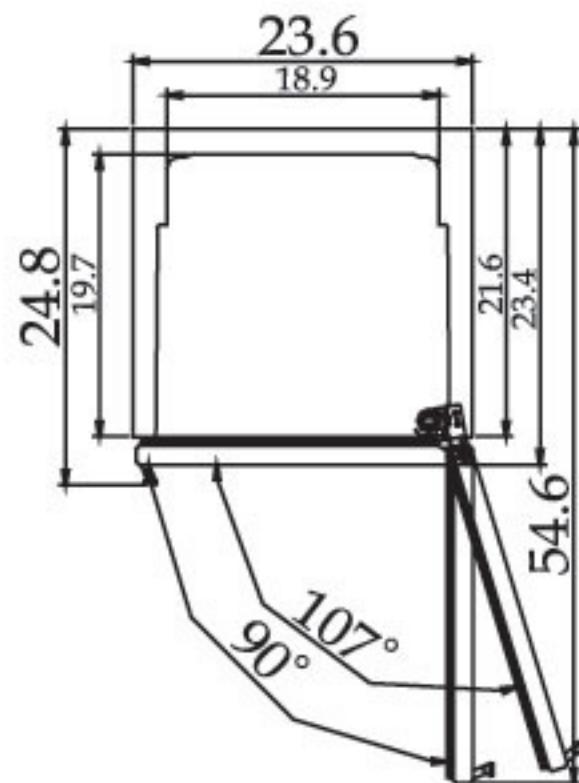

TGM-14RV PLAN VIEW

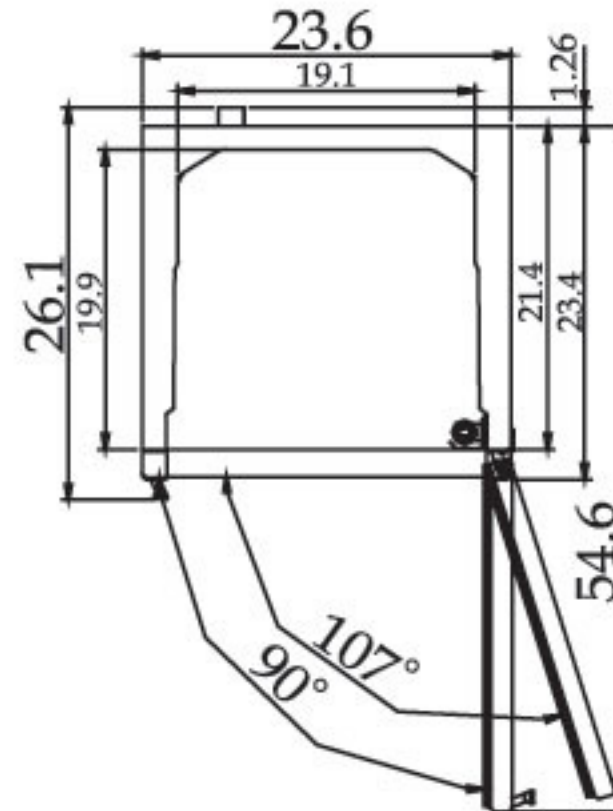

TGM-22RV PLAN VIEW

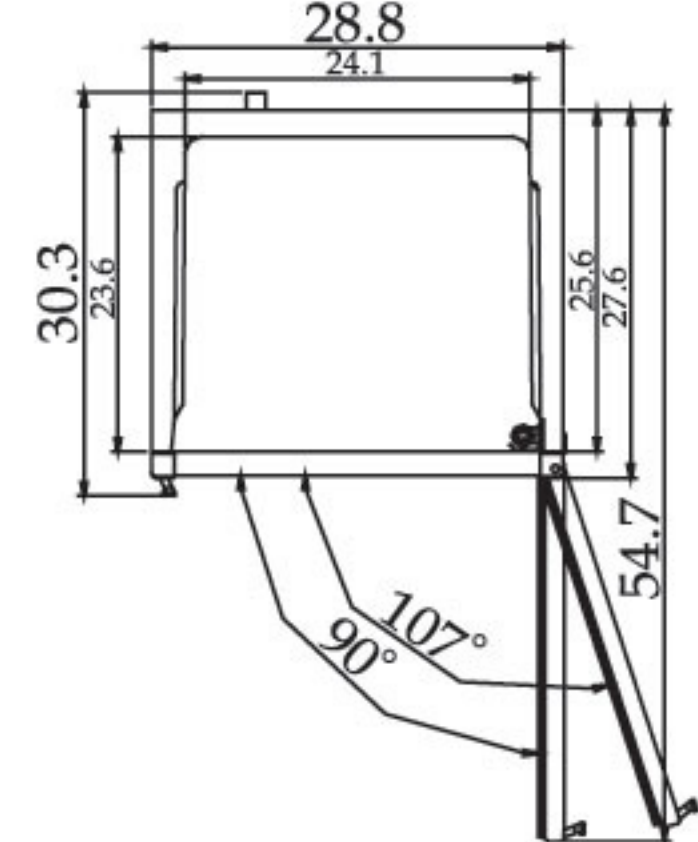

(unit : inch)

TGM-5R SIDE VIEW

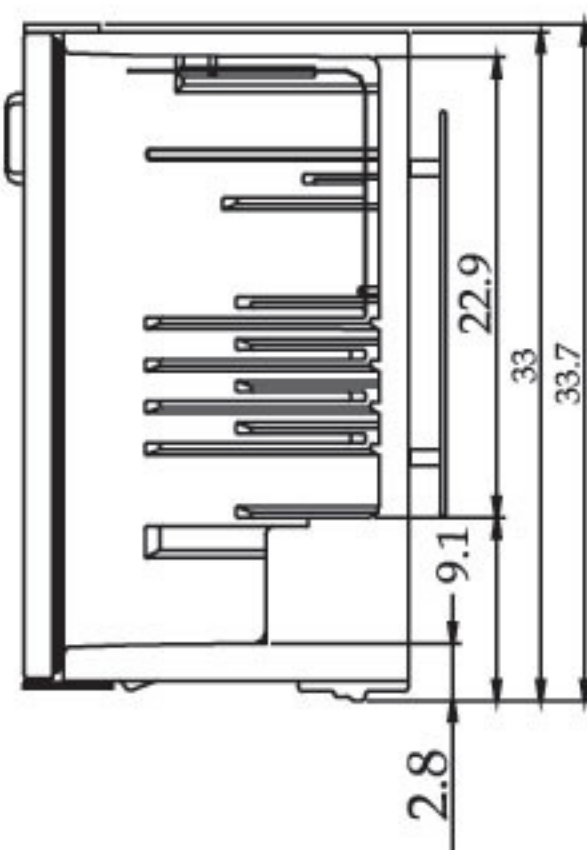

TGM-11RV SIDE VIEW

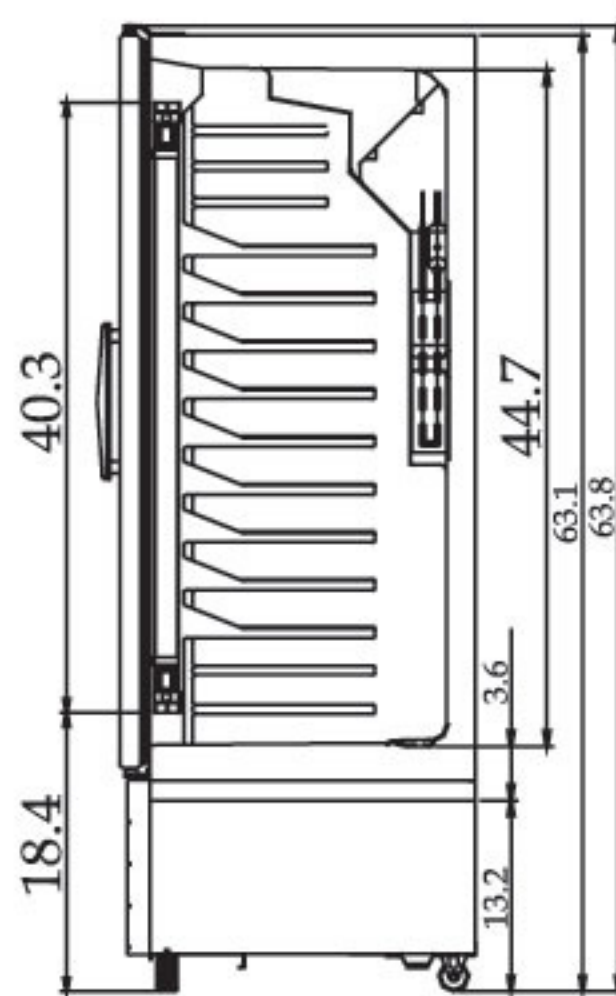

TGM-14RV SIDE VIEW

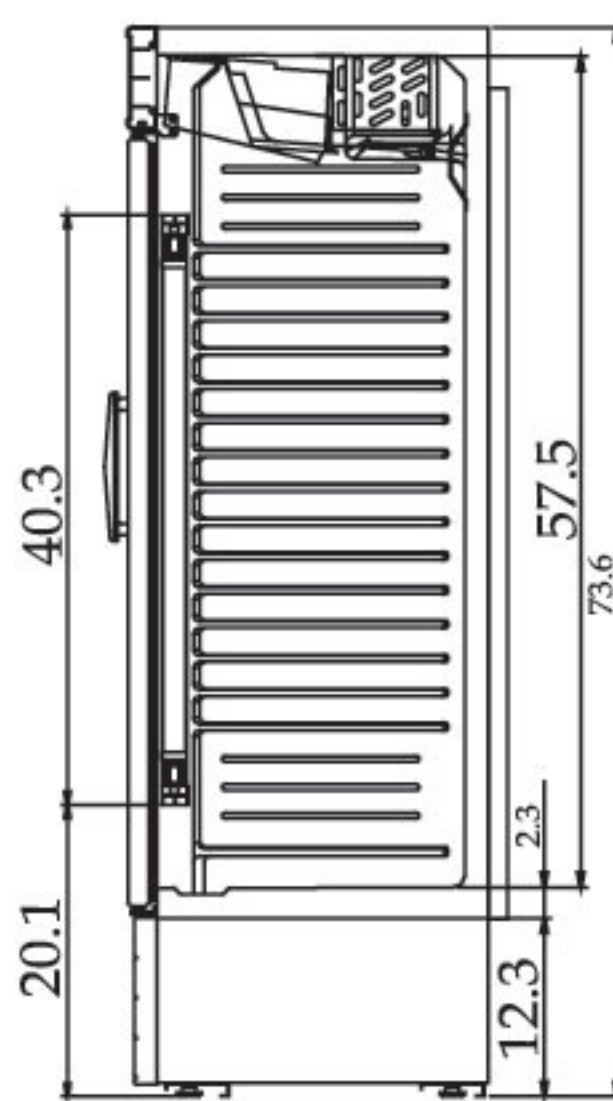

TGM-22RV SIDE VIEW

