

REFRIGERATOR MANUFACTURER
Turbo air
 more durable, efficient, beautiful

4184 E. Conant St.
 Long Beach, CA 90808
 Tel. 310-900-1000
 Fax. 310-900-1077
www.turboairinc.com

Project :	
Model # :	
Item # :	Qty :
Available W/H :	
Approval :	

Ice Cream Freezer

*Ice Cream Merchandisers
 Horizontal / Chest Freezers*

Model : TSD-27CF



FEATURES / BENEFITS

■ **ENVIRONMENTALLY FRIENDLY, EFFICIENT REFRIGERATION SYSTEM**

Turbo Air's freezers are designed with oversized and balanced environmentally friendly R-134A (CFC Free) refrigeration system. These include large evaporators and condensers for faster freezing and greater efficiency throughout the cabinet.

■ **TEMPERED, ENERGY SAVING LOW EMISSIVITY GLASS SLIDING TOP**

Reduced outer heat gain and lowers energy consumption. It enhances energy efficiency and minimizes condensation.

■ **ATTRACTIVE CURVED GLASS LIDS**

Optimize eye-catching display and impulse sales. Economical size and design for convenient access and fast service in high traffic area.

■ **EASY TEMPERATURE CONTROL MODE IS ENERGY EFFICIENT**

There is no need to reach inside the freezer to control the temperature. External temperature control knob allows easy adjustment and keeps cold air inside saving energy.

■ **HIGH-DENSITY POLYURETHANE INSULATION**

The entire cabinet structure is foamed-in-place using high density, CFC free polyurethane insulation.

■ **FREEZER HOLDS -9°F ~ 11°F FOR THE BEST IN FROZEN FOOD PRESERVATION**

■ **MANUAL DEFROST SYSTEM**

■ **WIRE BASKETS COME STANDARD**

■ **WHITE, ANTI-RUST COATING ON THE EXTERIOR REDUCES FINGERPRINTS**



Model	Sliding Door	CU./FT.	Baskets	HP	AMPS	Crated Weight (lbs.)	L x D x H* (inches)
TSD-27CF	2	4.9	2	1/5	2	107	27 ³ / ₈ x 23 ³ / ₈ x 31 ¹ / ₂

Model : TSD-27CF

ELECTRICAL DATA	
Voltage	115/60/1
Plug Type	 NEMA-5-15P
Full Load Amperes	2
Compressor HP	1/5
Cord Length ft.	7
Refrigerant	R-134A
DIMENSIONAL DATA	
# of Doors	2
Net Capacity cu. ft.	4.9
Ext. Length Overall in.	27 ³ / ₈ (694mm)
Ext. Depth Overall in.	23 ³ / ₈ (595mm)
Ext. Height Overall in.*	31 ¹ / ₂ (800mm)
Int. Length Overall in.	22 ¹ / ₄ (566mm)
Int. Depth Overall in.	18 ³ / ₈ (466mm)
Int. Height Overall in.	20 ⁷ / ₈ (531mm)
Gross Weight lbs.	107
Net Weight lbs.	99
# of Baskets	2
Net Capacity Gal.	36.5

Design and specifications subject to change without notice.
Actual shipping weight may differ due to extra packing materials for product protection.
* Height does not include 3-1/2" for caster height.

- **WARRANTY : 1 Year Parts and Labor Warranty**
Additional 4 Year Warranty on Compressor
- **NO PLUMBING REQUIRES**
- **SELF-CONTAINED SYSTEM**
- **1.5" DIA. CASTERS STANDARD (TSD MODELS)**

PLAN VIEW

(unit : inch)

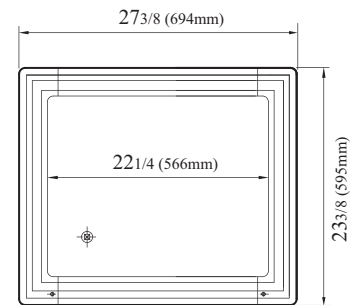

PLAN VIEW

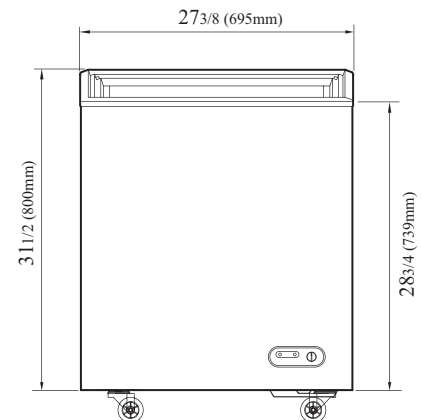

FRONT VIEW

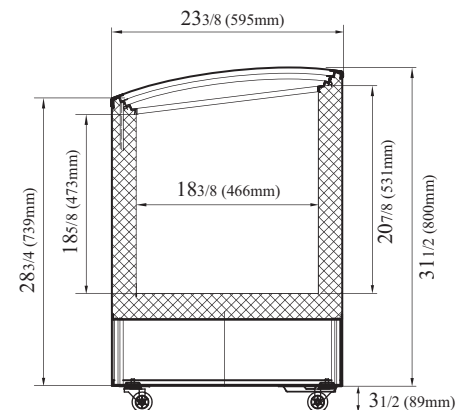

SIDE VIEW

Ver.201401



- Turbo Air : 800-627-0032
- GK : 800-500-3519
- Warranty : 800-381-7770
- AC : 888-900-1002