

Our recommendations for lubrication and cleaning are as follows:

Hinge System:

- **Save-T Hinge** - Remove hinge covers and wipe off old grease and apply new grease. Use wheel bearing type grease. **DO NOT OVER GREASE.** Tighten all loose hinge fasteners. Replace covers. Procedure should be done every 6 months.
- **Door Panel(s) and Gasket(s)** - Using a sponge or soft cloth, wash door panel and gasket with dishwashing detergent. Solution should be 1 part detergent to 50 parts water. **DO NOT USE ANY TYPE OF SPRAY CLEANER, ACETONES, CHLORINATED SOLVENTS OR OTHER CHEMICALS OF THIS TYPE.** Dry with soft cloth or towel. Apply plastic treatment, such as ARMOR-ALL, to the gasket(s).
- **Window Cleaning** - Wash the window with a mild soap or all-purpose glass cleaner. Dry with soft cloth. **DO NOT USE SOLVENTS, BLEACH OR PETROLEUM BASED PRODUCTS.** We recommend and sell Novus® brand scratch remover. It will remove scratches from windows.

NOTES:



5350 Campbells Run Road
Pittsburgh, PA 15205-9738

412-787-9750



SERVICE-PRO™

RESTAURANT SWINGING DOORS

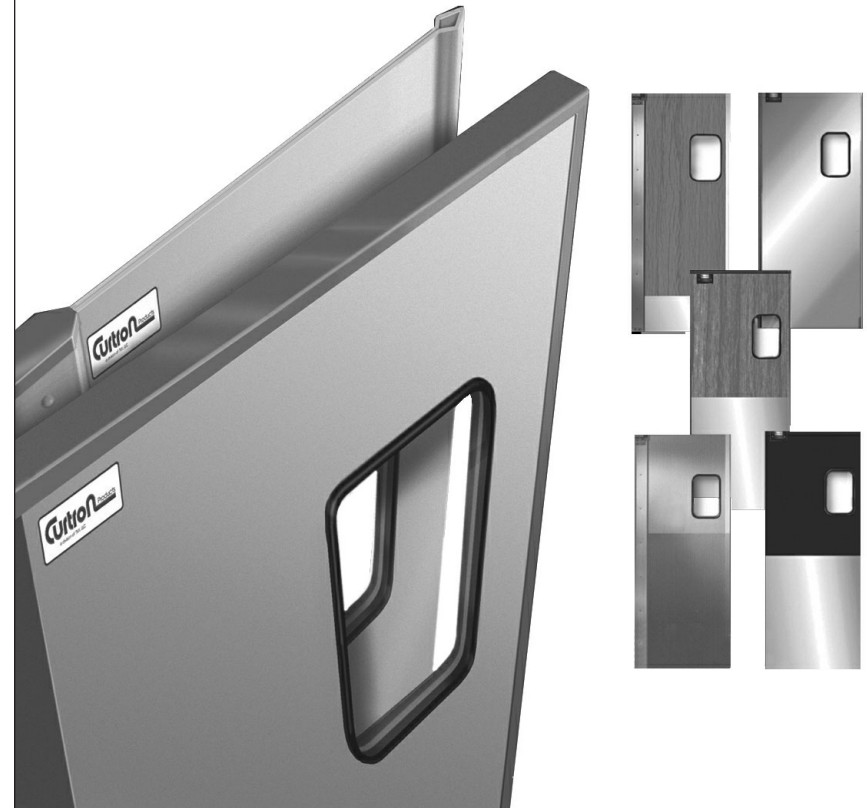

INSTALLATION INSTRUCTIONS

and MAINTENANCE GUIDE

- **SERIES 20** with **Save-T Hinge**
- **SERIES 30** with **Save-T Hinge**

Thank you for choosing a Curtron quality product.

Your SERVICE-PRO™ Swinging Door was manufactured to your specific width and height. Although installation is not complicated, you might need a helper depending on the type of door and hinge.

Check doorway jamb and lintel for plumb and squareness.

Note The jamb and lintel must be at least 4½" wide – square & plumb.

Important Construction must be at least double 2"x 4" or equivalent. Hollow metal jambs should be reinforced at hinge locations.

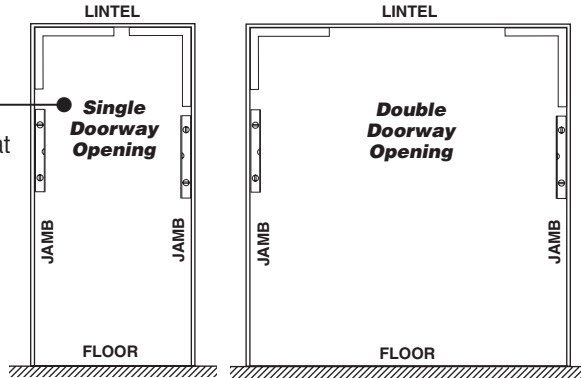

▼ SERIES 20 and SERIES 30 with Save-T Hinge

1 Remove both side covers on the top hinge.

2 Remove the 2 nuts and bolts from the top hinge cam plate.

3 Remove the "L" bracket from the top hinge assembly.

4 Place the "L" bracket in the center of the top corner. Mark the 6 mounting holes. Drill the 7/32" holes for steel construction and 3/16" for wood construction and mount the bracket with the screws provided.

5 Place the bottom hinge pin bracket on the lower corner of the jamb. Make sure the hinges are inline. Mark and drill the mounting holes. The floor holes could involve anchors and bolts (not provided). Mount the bracket with the screws provided.

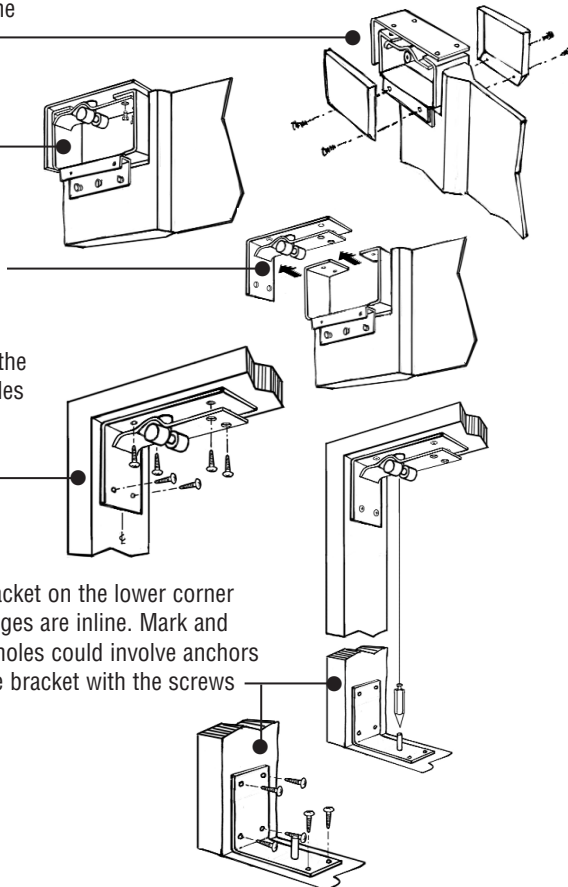

6 Position the door so the lower pin receptacle on the bottom of the door is on the pin that is attached to the bottom "L" bracket. Then position the top hinge assembly so it rests on the top of the cam bar.

7 Replace the 2 nuts and bolts. Do not completely tighten until the door panel is totally aligned.

8 Reposition door panel in the opening by adjusting the panel front-to-back and side-by-side so the door hangs as desired. Then tighten all screws and bolts.

9 Finally, replace the 2 side covers.

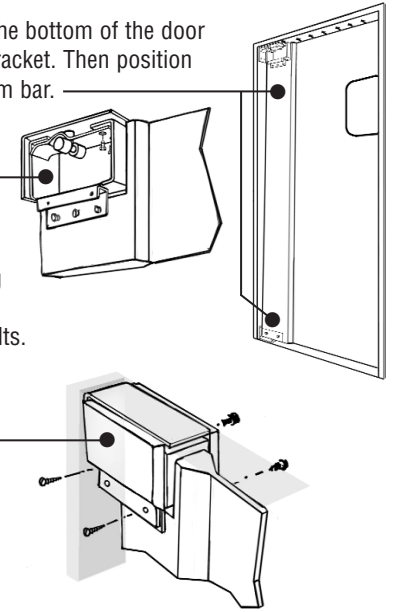

Maintaining your Curtron SERVICE-PRO™ Door

A regularly maintained door is the easiest way to ensure trouble-free operation of your Curtron SERVICE-PRO Swinging Door. Inspection, lubrication and cleaning are recommended every six months.

- The door(s) and seals should be inspected visually.
- Gaskets should be checked for cuts and tears.
- Hinges should be securely fastened.
- The door should open and close freely.
- When closed, the door should be centered in the opening.
- When closed, double doors with gaskets should also seal in the middle.
- Impact plates, kick plates and hinges should be examined for loose attachment.

Lubrication and cleaning instructions on page 4 ►