

Item No.

Consistent Pasta, Batch After Batch, With The Anets Pasta Pro

Use the Pasta Pro to batch cook, cook to order, or reheat pasta or any product cooked in water. Precise controls regulate the boil for perfectly cooked product. Unique "Power Burst" feature controls the BTU input at the flip of a switch. Rapid boil or quick reheat with the full 150,000 BTU input or reduce to 75,000 BTU to maintain a gentle simmer or re-heat temperature. Control cook times with optional built in timers or automatic basket lifts. Add a rinse station and faucet for a complete pasta station.

STANDARD FEATURES

- Cook pot and burner tubes are special marine grade stainless steel specifically for water applications
- "Power Burst" feature allows operator to control the BTU input, providing energy saving input or quick reheat when necessary
- Built-in manual water-fill enables the operator to adjust water input for continuous refill (option). Manual water control eliminates the need for complicated floats and costly components
- Tube type design assures maximum heat input across the 18" cooking area
- Overflow area safeguards against accidental overflow
- Skimming area provides a place to continuously remove starch build up
- Front drain tray



GPC-18 shown with optional adjustable continuous water fill, rinse station, hot and cold faucet, split bulk baskets and casters.



SPECIFICATIONS

- Model
- Certification
- BTUH
- Gas Pressure
- Gas Connection
- Electrical Requirements
 - GPC-18
 - GPC-18AA
- Thermostat
- Temperature Range
- Burners
- Hi-Limit
- Safety Pilot
- Pulse Ignitor
- Cookpot
- Cookpot Tubes
- Cabinet
- Water Capacity

STANDARD ACCESSORIES

- Rack type basket support
- Front drain tray
- 6 Adjustable chrome plated legs

OPTIONS AND ACCESSORIES

- Adjoining rinse station (RSF18)
- Hot and cold water faucets
- Adjustable continuous water fill
- Fully automatic twin lifts
- 15 minute timers with buzzers
- Low temperature thermostat for rethermalizing or blanching (160°F to 212°F) (71°C-100°C)
- 6 Casters

GPC-18, Basic
 GPC-18AA, Fully automatic twin lifts
 NSF, ETL
 Min. 75,000/Max. 150,000

NG 3.5 WC, LP 10" WC 3/4
 3/4" NPT

120V, 60Hz, 1PH, 2 Amps
 120V, 60Hz, 1PH, 5 Amps
 Solid state
 190°F to 212°F (88°C-100°C)
 160°F to 212°F (71°C-100°C) (optional)

Atmospheric pre-mix
 Safety control turns off main gas supply at 250°F (121°C)

100% gas shut off valve
 Battery Powered Ignitor
 Marine grade stainless steel
 Marine grade stainless steel
 Stainless steel
 16.5 gallons

NOTE: Baskets must be ordered separately

BASKETS

- Bulk
- Split bulk (Twin)
- 5^{3/4}" Round
- Portion rack with (9) 10oz plastic portion cups

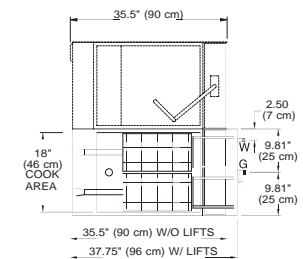

Top View

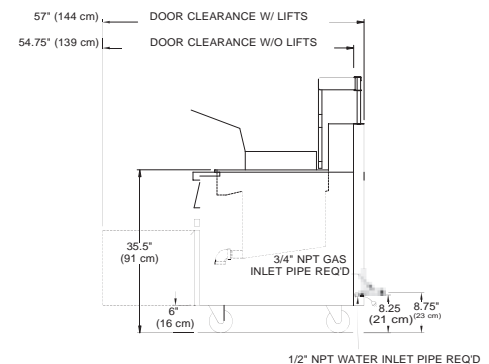

Side View

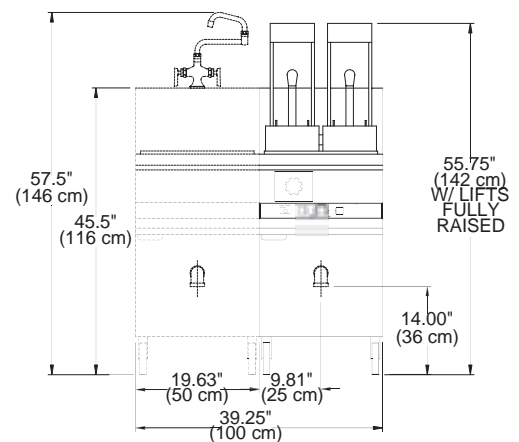

Front View

Note: Diagrams include optional rinse station with faucet (RSF18).

Frypot has a 1 year Warranty



ANETS INC PO BOX 501, CONCORD, NH 03302-0501
 509 ROUTE 3A, BOW, NH 03304 TEL: 603-225-6684, FAX:603-225-8497
 L10-521 R1 www.anets.com

We reserve the right to change specifications without notice and without incurring any Obligation for equipment previously or subsequently sold.