



ULTRA-MAX™ RADIANT CHAR-BROILERS

Models 8124RCB, 8136RCB, 8148RCB, 8160RCB & 8172RCB

Features/Benefits:

- ★ Heavy-Duty Ultra-Max™ Radiant Gas Char-Broilers are designed for the most demanding foodservice applications. Ultra-Max™ Char-Broilers deliver maximum performance and provide years of maintenance-free operation.
- ★ Heavy duty, high strength steel radiant transfers maximum heat to steak, chicken, burgers, fish and other menu items. Our exclusive steel radiant with flavor enhancing grooves delivers more heat than traditional cast iron radiants and will not bend or crack due to thermal shock. Three year warranty on Star's exclusive steel radiants!
- ★ 30% more cooking space with our high capacity design to meet all your back-of-the-house broiling needs.
- ★ Available in 24", 36", 48" and 60" widths to fit any foodservice operation's space requirements.
- ★ High performance 20,000 BTU straight tubular steel burners every 6" of width provide more heat to cook faster and sear in flavor, better heat distribution, and more sectional control.
- ★ Heavy-Duty cast iron grates can be individually positioned (flat or slanted) to accommodate a variety of broiling needs. Plus, our grates are reversible with a thin side for searing and a thick side for more delicate menu items.
- ★ Large capacity stainless steel water pan for easy clean up.
- ★ Stainless steel, 5" high, tapered splash guard maintains cleanliness.
- ★ Gas convertible in the field with conversion kit supplied with each char-broiler. Units are shipped Natural Gas.
- ★ Cool to the touch stainless steel bull nose front provides knob protection and comfortable work zone.
- ★ Heavy-duty four inch adjustable legs to match the height of other Ultra-Max™ equipment in your line.
- ★ Floor models available with custom equipment stands.
- ★ Optional items include 7" extended plate shelf and round steel grates.

Applications:

Ultra-Max™ radiant char-broilers are designed for high volume and reliability. Whether it's steak, chicken, hamburger, shish kabobs or other menu items; Star's heavy-duty Ultra-Max™ char-broilers will fulfill your back-of-the-house cooking requirements and more!

Quality Construction:

Ultra-Max™ line of radiant char-broilers feature stainless steel side panels, front panel, bull nose, drip pan, splash guard, and grease trough. Char-broilers have heavy-duty full polycarbonate graphic panel. Steel tubular burners every 6" with adjustable valves and standing pilot. Radiants are heavy-duty steel designed for maximum heat transfer and durability. Cooking surface consists of heavy duty, cast iron grates adjustable to flat or slanted positions. Heavy-duty legs are 4" with a 1-5/8" adjustment.

Warranty:

Ultra-Max™ Radiant Char-broilers are covered by a one year parts and labor warranty. In addition, Star's steel radiant is warranted for 3 years!



Model 8136RCB



Model 8136RCB

Shown with Optional Mobile Equipment Stand





ULTRA-MAX™ RADIANT CHAR-BROILERS **Models 8124RCB, 8136RCB, 8148RCB, 8160RCB & 8172RCB**

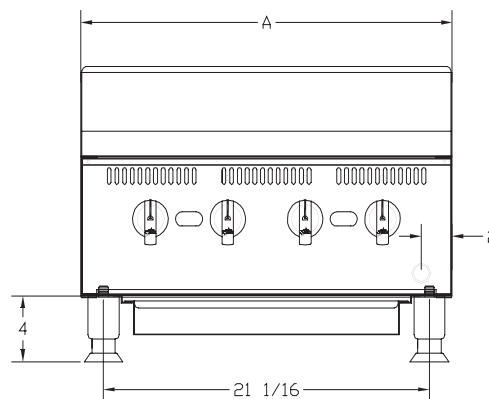
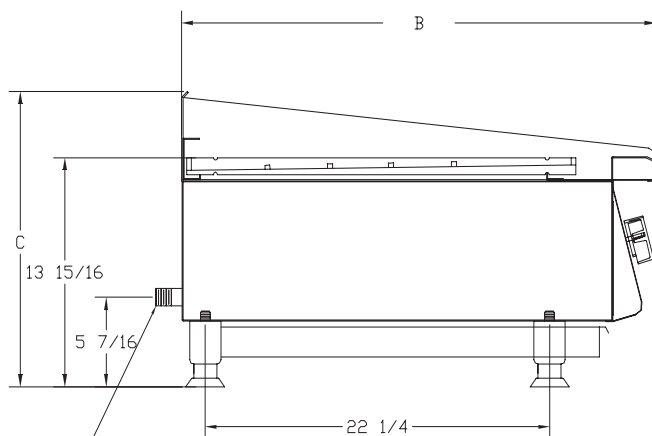

GAS INLET 3/4" NPT

Specifications

Model No.	Dimensions			No. Controls	BTU	Grid Area	Weight	
	(A) Width Inches (cm)	(B) Depth Inches (cm)	(C) Height Inches (cm)				Installed lbs (kg)	Shipping lbs (kg)
8124RCB	24" (61)	30-5/8" (77.8)	18" (45.7)	4	*80,000	603 sq. in. (3890 sq. cm) 23-7/8" x 25-1/4"	174 (78.9)	243 (109.4)
8136RCB	36" (91.4)	30-5/8" (77.8)	18" (45.7)	6	*120,000	906 sq. in. (5845 sq. cm) 35-7/8" x 25-1/4"	240 (108.9)	328 (147.6)
8148RCB	48" (121.9)	30-5/8" (77.8)	18" (45.7)	8	*160,000	1209 sq. in. (7800 sq. cm) 47-7/8" x 25-1/4"	314 (142.4)	399 (180)
8160RCB	60" (152.9)	30-5/8" (77.8)	18" (45.7)	10	*200,000	1512 sq. in. (9754 sq. cm)	386 (175.1)	503 (226.4)
8172RCB	72" (182.9)	30-5/8" (77.8)	18" (45.7)	10	*240,000	sq. in. (sq. cm)	485 (220.2)	625 (283.8)

*Units shipped Natural Gas but do include conversion kit for field conversion to LP gas.

Typical Specifications

Gas char-broiler is constructed of all stainless steel, front panel and sides. Units have 20,000 BTU natural and propane gas straight tubular stainless steel burner for every 6" (15.24 cm) of width and are controlled by an adjustable control valve and standing pilot. Steel radiant provides even heat distribution. Cooking surface is heavy duty cast iron grate type and is adjustable from flat to slanted. A stainless steel water pan, bull nose, 5" back splash are standard. Control knobs are protected by a stainless steel bull nose front. Char-broilers are supplied with heavy-duty 4" (10.2 cm) stainless steel high legs that have a 1-5/8" (4.5 cm) adjustment. Gas connection is 3/4" N.P.T. male with a convertible pressure regulator provided. Units are approved for installation in non-combustible locations and are UL Certified to NSF Standard 4 and Classified cULus listed. Printed in the U.S.A.